

Magnetic dirt separators

M-Pure Magnetic Dirt Separator

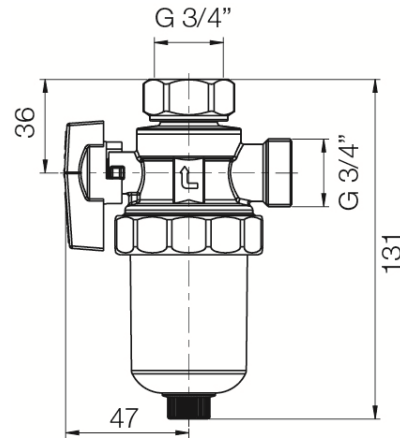

Code	Dimensions	EAN13
6096970	GZ 3/4"	5902273570912

Code	Kv (m3/h)	Magnet power (Gs)	The mesh size of the filter mesh (µm)
6096970	3,01	8700	800

Product usage:

Central heating, solar and air-conditioning systems where the working medium is water or water-glycol solution (up to 50%)

Type:

Dirt separators

Technical data/Operating parameters:

Max pressure: 0,5 MPa (for 65°C)
 Max temperature: 90°C (for 0,4 MPa)
 Min temperature: 0°C (for 0,5 MPa)

Guarantee:

25-year

Used materials:

Connection flange, drain valve, magnet cover, vent valve: brass;
 body, separator bowl: plastic;
 inlay: steel mesh;
 sealing gasket for separator bowl: EPDM;
 magnet: N40M

Finish:

Connection flange, air vent, drain valve: nickel